



# Legislative Report

TOI already gearing up for 2010

**W**ITH A SUCCESSFUL FALL VETO SESSION just behind us, the Township Officials of Illinois is already gearing up for the 2010 spring session of the Illinois General Assembly. Most attention of late has been focused away from Springfield and on the campaign trail as dozens of candidates eye spots on the statewide ticket after the February 2 primary election. But once that takes place, expect a busy—and contentious—legislature for the following four months.

The General Assembly reconvenes on January 12, but not much will occur until they return for good on February 3. Then it's pretty much action every week straight through the spring recess during the last week of March and the first week of April. Then it's full time again until the tentative adjournment date of May 7.

The contention will stem from dealing with a state budget deficit of around \$12 billion. Once again, Illinois faces dire spending and revenue prospects, and none of the solutions will be easy. There's no guarantee that legislators, many facing tough fall election campaigns, will be any more eager to embrace those tough decisions than they have in the recent past. It could be a long spring!

TOI is still awaiting Governor Pat Quinn's action on **House Bill 644** (sewer cutoff bill), which passed in October, as well as **Senate Bill 1371** (township AED exemptions). In the meantime, we are already gearing up for 2010 as our legislative committee puts together our agenda for the spring. Next month's article will focus on those issues.

In the meantime, here is a recap of bills of importance to TOI from last spring and fall and their current status:

- **HOUSE BILL 564** (*Rep. Osmond; Sen. Althoff*) remedies a situation where a city and a township are coterminous and a city council is exercising powers that would ordinarily be exercised by the township board and allows the council by a ¾ vote to authorize the township supervisor to preside over portions of the city council meetings

when addressing township issues. *Passed both houses; signed by the Governor (P.A. 96-0241).*

- **HOUSE BILL 621** (*Rep. Fortner; Sen. Hultgren*) adapts language to the Township Code that would authorize township boards to deal with mowing grass, trimming or removing nuisance trees or bushes on neglected property. *Passed both houses; signed by the Governor (P.A. 96-0564).*
- **SENATE BILL 1379** (*Sen. Sullivan; Rep. Tracy*) increases the threshold for a township highway commissioner to have a pecuniary interest in lease contracts if the aggregate total of the contracts is less than \$2,000 (was \$1,000) with the approval of the town board of trustees or the highway board of auditors. *Passed both houses; signed by the Governor (P.A. 96-0422).*
- **HOUSE BILL 644** (*Rep. Verschoore; Sen. Haine*) adds township sewer service systems as entities that may, along with municipalities and sanitary districts that now can, discontinue water service for non-payment of sewer bills. *Passed the House; passed both houses and awaiting action by the Governor.*
- **HOUSE BILL 476** (*Rep. Winters; Sen. Viverito*) provides for a proportional allotment of motor fuel tax receipts to **all** townships, rather than to just those that levy at .08%. *Passed the House; defeated in Senate committee.*

In addition to TOI's specific agenda, there were several measures that received the support of townships, including:

- **SENATE BILL 78** (*Sen. Clayborne; Rep. Black*) would more precisely define what constitutes a "mobile home" for purposes of tax assessment and inspections. *Passed the Senate; held in House committee and pending for spring.*

- **SENATE BILL 1371** (*Sen. Crotty; Rep. Burke*) exempts outdoor “physical fitness” facilities owned or operated by a municipality or township from the Physical Fitness Facility Medical Emergency Preparedness Act. *Passed both houses; awaiting action by the Governor.*
- **HOUSE BILL 641** (*Rep. Mautino; Sen. Wilhelmi*) extends the time period for expenditure of moneys apportioned by IDOT to counties for the use of road districts for bridge construction. *Passed both Houses; signed by the Governor (P.A. 96-0366).*
- **SENATE BILL 49** (*Sen. Althoff; Rep. Ryg*) increased state reimbursement to local road districts for the purchase of road salt during the 2008-2009 season. *Passed the Senate; held in House committee.*
- **SENATE BILL 43** (*Sen. Clayborne; Rep. Fritchey*) expands the definition of public works for the purposes of prevailing wage laws to include projects funded by public grants or those in TIF districts and enterprise zones. *Passed the Senate; held in the House.*
- **SENATE BILL 189** (*Sen. Raoul; Rep. Madigan*) expands the scope of the Freedom of Information Act by broadening definitions of what must be provided by governments, requires designation of an employee, officer or member as an FOI officer, requires computer training of that person, and creates an FOI mitigation section within the Illinois Attorney General’s office, as well as other provisions. *Passed both houses; signed by the Governor (P.A. 96-0542).*

And other measures that we opposed:

- **SENATE BILL 1268; HOUSE AMENDMENT #2** (*Rep. Franks*) would have provided full access to heavy trucks on local roads and bridges with no limits for up to five miles. *Defeated in House committee.*

And one that was amended to meet TOI’s concerns:

- **SENATE BILL 1471** (*Sen. Emil Jones; Rep. Davis*) would provide strict regulation of private, for-profit cemeteries. It originally included all cemeteries, including those operated by townships, but was amended to exclude township, municipal and religious cemeteries. *Passed the House in the fall veto session; held in the Senate.*

## RAISING THE BAR ON QUALITY. STANDARD.

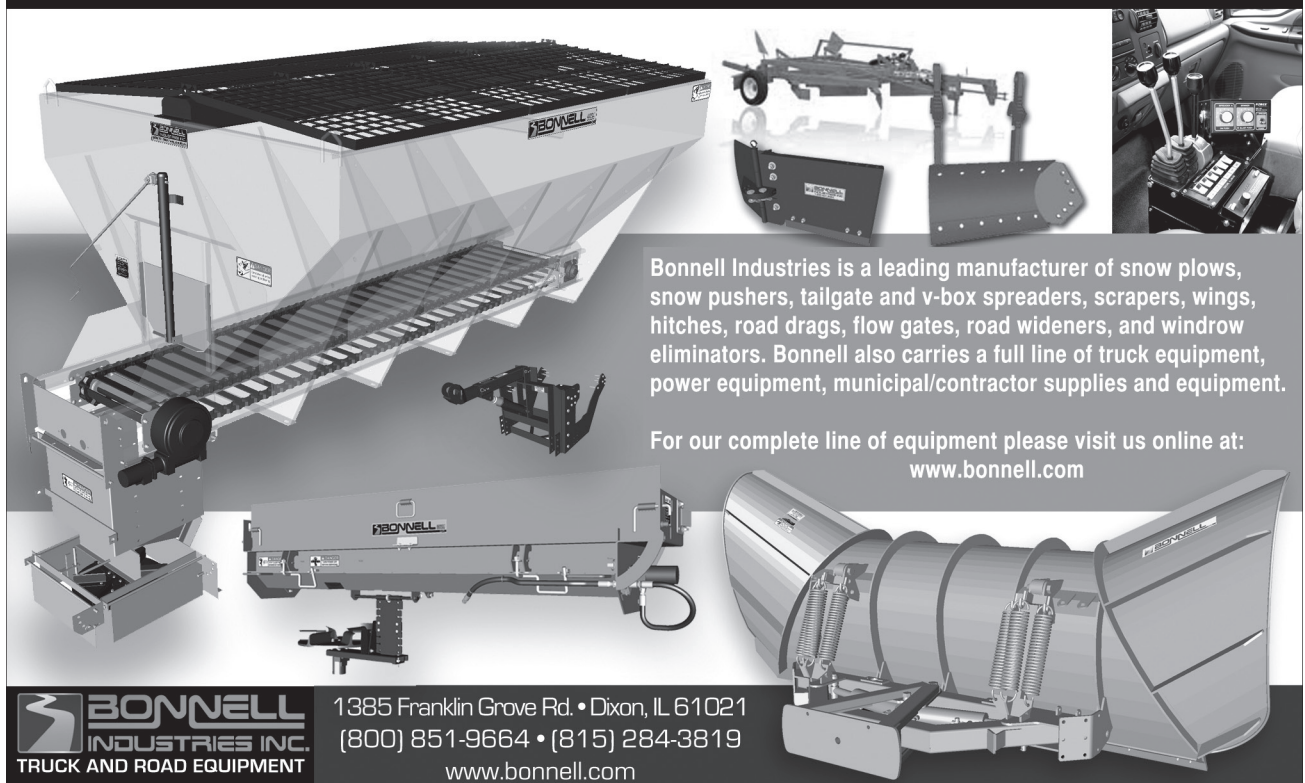

Bonnell Industries is a leading manufacturer of snow plows, snow pushers, tailgate and v-box spreaders, scrapers, wings, hitches, road drags, flow gates, road wideners, and windrow eliminators. Bonnell also carries a full line of truck equipment, power equipment, municipal/contractor supplies and equipment.

For our complete line of equipment please visit us online at: [www.bonnell.com](http://www.bonnell.com)

**BONNELL INDUSTRIES INC.**  
TRUCK AND ROAD EQUIPMENT

1385 Franklin Grove Rd. • Dixon, IL 61021  
(800) 851-9664 • (815) 284-3819  
[www.bonnell.com](http://www.bonnell.com)